

Flow Cytometry at CNC-Polo I:

FACSCalibur (Becton Dickinson) - 4 colours

Software: Cell Quest
ModFit LT

Performance

Fluorescence Sensitivity	Estimated detection limit is 750 molecules of equivalent soluble fluorescein
Fluorescence Resolution	Coefficient of variation in FL2-Area of < 3%, full peak for propidium iodide-stained chicken erythrocyte nuclei
Forward and Side Scatter Sensitivity	Sensitivity enables the separation of fixed platelets from noise
Forward and Side Scatter Resolution	Scatter performance is optimized for resolving lymphocytes, monocytes and granulocytes

Fluidics

General operation	Front panel control with three modes: RUN, STNDBY, and PRIME; standby mode for conserving sheath fluid when no sample tube installed
Fluid reservoirs	2 Lt sheath and waste containers
Sheath pressure	4.5 psi
Sample flow rates	Regulated and monitored pressure difference between sheath and sample; particle velocity in flow cell approximately 6 meters/second Low = 12 µL/min Medium= 35 µL/min High = 60 µL/min
Maximum acquisition rate	2,000 events/sec
Recommended sample concentration range	Single-cell suspension of 1×10^5 to 2×10^7 particles/mL

Optics

Laser	Detector	Filter (nm)	Fluorochrome
Blue (488 nm)	FL1	BP 530/30	FITC , GFP, CFSE, DCFH
	FL2	BP 585/40	PE , PI, PE-Texas Red
	FL3	LP 670	PerCP-Cy5.5, PE-Cy5.5, PE-Cy7, PI, 7-AAD
Red (635nm)	FL4	BP 661/16	APC , Cy5, TOTO-3, Alexa 635

Emission Optics

Collection lens	Optical gel-coupled to quartz cuvette
Fluorescence detection	4 PMT detectors (Standard) + 1 optional 3 wavelengths detected from 488-nm laser: 530/30 nm 585/42 nm >670 nm One wavelength detected from optional 633-nm laser: 661/16 nm
Forward scatter detection	Photodiode with 488/10 bandpass filter
Side scatter detection	PMT with Brewster-angle beam splitter

Optical Layout

The following figure show a schematic diagram of the FACSCalibur optical layout, with detectors (FSC, SSC, FL1-4) and example fluorochromes that can be used when designing experiments for this instrument.

The following figure shows a schematic representation of the FACSCalibur optical layout.

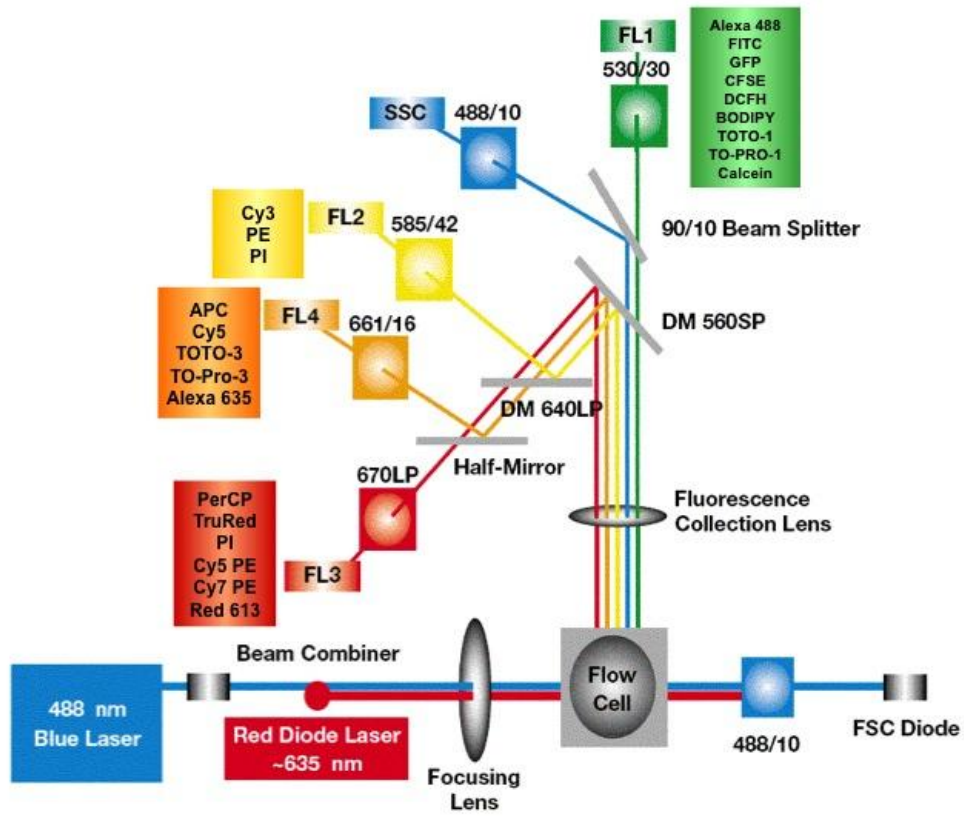

Partec CyFlow® space - 7 colours

Software: FloMax®

Performance

Fluorescence Sensitivity	Superior fluorescence sensitivity of < 100 MESF (FITC) and < 50 MESF (PE)
Fluorescence Resolution	Coefficient of variation of about 2% on all fluorescence channels
Forward and Side Scatter Resolution	Going to nano-resolution in the scatter channel

Fluidics

Flow Cuvette	Synthetic quartz flow cuvette (350 x 200 µm) for laminar sample transport with sheath fluid for fluorescence, forward and side scatter light detection
Sample Delivery	Computer controlled precision syringe pump for contamination-free sample transport. Built-in air pressure for sheath fluid. Sheath fluid pressure is adjustable from 0-300 mbar (computer controlled). Default setting: 200 mbar
Sampling Volume	Continuous up to 1500 µl; 200 µl for precise absolute counting
Flow Rates	Sample volume speed adjustable continuously between 0 and 50 µL/s. Sheath fluid pressure continuously adjustable
Maximum acquisition rate	52,000 events/sec
Fluidics Volume	2 Lt reservoirs for sheath fluid and waste
BioSafety System	Avoids sample droplets and sample cross contamination (computer controlled)

Optics

Laser	Detector	Filter (nm)	Fluorochrome
Blue (488 nm)	FL1	BP 536/40	FITC , GFP, Alexa Fluor 488, Syto 9
	FL2	BP 590/50	PE , YFP
	FL3	BP 675/10	PE-Texas Red
	FL4	LP 748	PE-Cy5
Red (635nm)	FL5	BP 675/10	APC , Cy5, TOTO-3, Alexa 635
	FL6	LP 748	APC-Cy7
Violet (405 nm)	FL7	BP 455/25	Alexa Fluor 405 , Pacific Blue

Emission Optics

Fluorescence detection	Nine optical parameters, each with its own photomultiplier tube (PMT), including forward scatter PMT and side scatter PMT
Optical parameters	FSC, SSC, FL1-FL7

The following figure shows an example selection of fluorochromes for the CyFlow® space Light source system.

Type of laser	Fluorescence Channel	Fluorochromes
blue solid state laser 200 mW 488 nm	GREEN	FITC, GFP, Alexa Fluor® 488, SYTO 9
	ORANGE	PE, YFP
	ORANGE RED	PE-Texas Red®
	RED	PE-Cy5, PE-Cy5.5, PerCP, PerCP-Cy5.5, ECD, EB
	INFRA RED	PE-Cy7
red diode laser 25 mW 635 nm	RED	APC, APC-Cy5.5, SYTO 59-61, Alexa Fluor® 633, Alexa Fluor® 647
	INFRA RED	APC-Cy7
Option for 3rd light source:		
violet diode laser 50 mW 405 nm		Alexa Fluor® 405, Pacific Blue, Cascade, CFP

Optical layout

The following figure shows a schematic diagram of a CyFlow® space optical layout, with detectors (FSC, SSC, FL1-7).

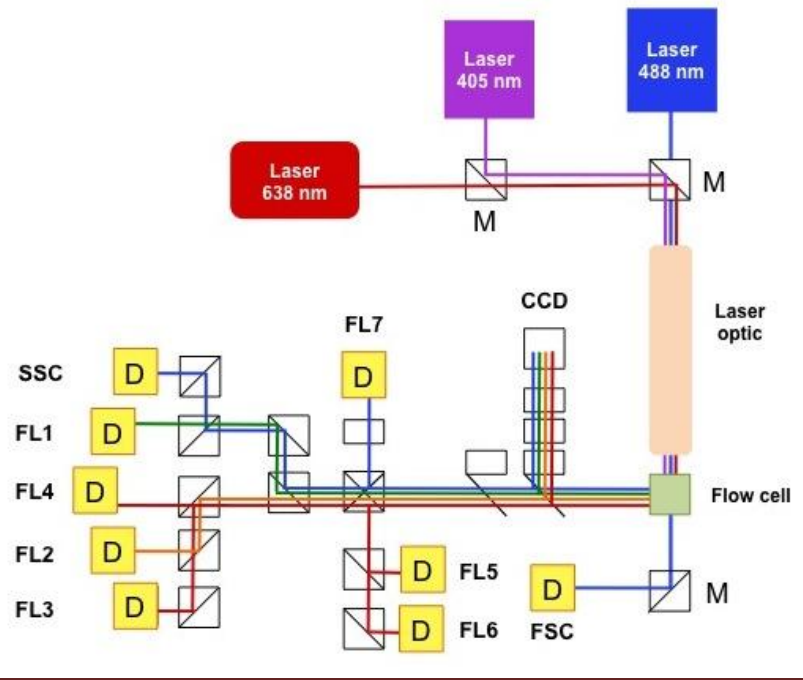

Electronics

Parallel real time signal processing for each of the optical channels with selectable linear, 3- or 4-decade logarithmic amplification (6-decade log amplifiers), pulse height, area and width analysis for doublet discrimination, 16 bit analog-to-digital converters, trigger to any parameter or all parameters.

The instrument is equipped with a CCD camera to monitor the particle flow and to check the focus of the objective.

Partec True Volumetric Absolute Counting

The Partec CyFlow® space allows the analysis of concentrations of samples by the method of True Volumetric Absolute Counting that is based on the precise measurement of a fixed sample volume by means of two electrodes. The following figure shows a schematic representation of the True Volumetric Absolute Counting Electrode principle.

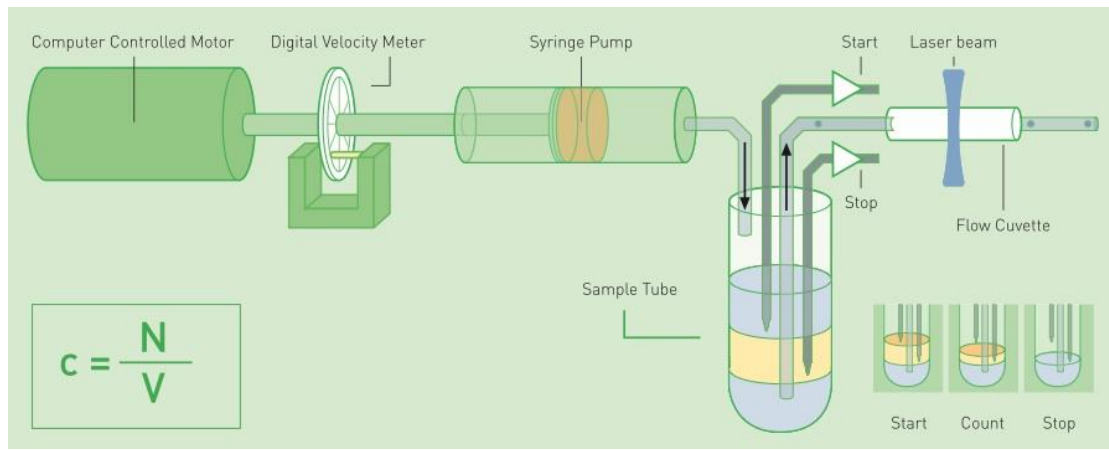

Partec Particle and Cell Sorter (PPCS)

The Partec particle and cell sorter, PPCS, serves as an optimized module for simplified and precise cell sorting. In order to overcome the problems of droplet sorters (biohazard, contamination) Partec has developed this closed sorting system. The PPCS sorting device can be sterilized safely. Any environmental contamination is completely avoided under normal operation conditions. In addition, the sorting action takes place smoothly. Fragile cells or large particles are sorted without any distortion and other forces acting on the cells during deflection. Long sorting runs (for several hundred milliliters of sample volume) are possible.

Sorting flow cell	Closed quartz type flow cell with 200 µm sorting channel for particle sizes up to 60 µm diameter
PPCS sorting control unit	Setting of sorting parameters for piezo crystal energy, delay, slope and hold time. Direct connection to CyFlow processor
Sorting speed	Input up to 15000 cells per second (maximum data acquisition rate), output for high purity (95%) of sorted fraction up to 300 cells per second. Highest purity (99%) with 100 cells per second
Sorting action	Piezo crystal for controlled particle deviation. Adjustable delay between point of analysis and deflection
Sort Collection Devices	One-way sorting to 3,5 ml, 55 × 12 mm tubes or to a sterile Shott flask

Partec Particle and Cell Sorter Principle of Operation

The sorting flow cell has a y-shaped capillary channel system. Beyond the measuring area (laser focus/lamp focus) the flow channel is divided into the waste and sort channel, respectively. The piezo crystal is located in the waste channel and generates high speed pressure waves while cells are detected in the software sort

regions. This pressure wave deflects all those cells out of the laminar flow into the sort channel outlet. The piezo can be driven several thousands times per second. The sample flow enters the sorter cuvette in a laminar stream, which is embedded in the sheath. This laminar flow is not disturbed during piezo action. Due to an exact timing condition the generated pressure wave acts only on the cell that travelled the illuminated light focal area. Any signal (laser forward or laser side scatter, laser or lamp induced fluorescence) or gate region is selectable for active sorting. The following figure shows a schematic representation of the sorter flow cell.

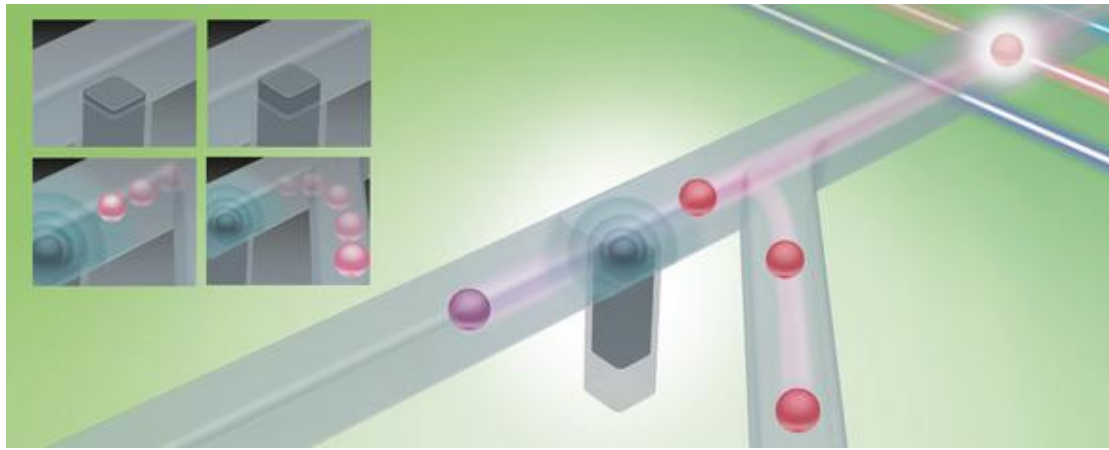

Flow Cytometry at CNC-UCBiotech:

Accuri™ C6 with autosampler (Becton Dickinson) – 4 colours

Software: Accuri C6

Performance

Fluorescence Sensitivity	FITC < 150; PE < 100 MESF values determining using Thermo Scientific Cyto-Cal™ Multifluor Plus Violet Beads
Fluorescence Precision	<3% CV for CEN
Scatter Resolution	Scatter Resolution Resolves human peripheral blood lymphocytes, monocytes and granulocytes
Data Acquisition Rate	10,000 events/second, maximum

Fluidics

Flow Cell	200 µm ID quartz capillary
Minimum Detectable Particle Size	0.5 µm
Minimum Sample Volume	50 µL for tubes or plates
Pre-Set Flow Rates and Core Sizes	Slow: 14 µL/min, 10-µm core Medium: 35 µL/min, 16-µm core Fast: 66 µL/min, 22-µm core
Custom Sample Flow Rates	10-100 µL/min
Custom Core Diameter	5-40 µm
Recommended Sheath Fluid	0.2-µm filtered DI water
Maximum Events per Sample	1 million events per well
Compatible Plate Types	Standard 96-well (flat, round, and v-bottom) plates
Processing Time	<90 minutes for 96-well plate, utilizing 30-second acquisition time per well

Optics

Laser Excitation	488 nm and 640 nm
Laser Profile	10 × 75 μm
Light Scatter Detection	Forward (0°, ±13°) Side (90°, ±13°)
Emission Detection	4 colors, user-changeable optical filters Standard set installed: <ul style="list-style-type: none"> • FL1 533/30 nm (eg, FITC/GFP) • FL2 585/40 nm (eg, PE/PI) • FL3 > 670 nm (eg, PerCP, PerCP-Cy5.5, PE-Cy™7) • FL4 675/25 nm (eg, APC)
Optical Alignment	Fixed Alignment

Laser	Detector	Filter (nm)	Fluorochrome
Blue (488 nm)	FL1	530/30	FITC , GFP, CFSE, BB515
	FL2	585/40	PE , PI, PE-Texas Red
	FL3	670 LP	PerCP-Cy5.5, PE-Cy5.5, PE-Cy7, 7-AAD
	FL3	675/25	PerCP-Cy5.5, PE-Cy5, 7-AAD
	FL4	675/25	PerCP-Cy5.5, PE-Cy5
	FL3	610/20	PI, PE-Texas Red
	FL4	610/20	PI
	FL3	630/30	7-AAD
	FL4	630/30	PE-Texas Red
	FL3	780/60	PE-Cy7
Red (648nm)	FL4	675/25	APC , Alexa-647, PE-Cy5
	FL3	780/60	APC-Cy7

LSRFortessa (Becton Dickinson) – 10 colours

Software: BD FACSDiva 6.2

System overview

The BD LSRFortessa 1 *cell analyzer* is a benchtop digital flow cytometer equipped with a fixed-alignment flow cell that is gel-coupled to the collection optics. It has three spatially separated lasers - 405 nm, 488 nm and 640 nm. Its primary function is to characterize complex populations of cells. Individual cells pass single file through a stream, which is interrogated by the three lasers with the emitted light being detected by photomultiplier (PMT) tubes. The system electronics calculates the time it takes a single cell to pass through each laser intercept and assigns the signal of each PMT to the appropriate cell. Besides fluorescence, the physical properties of the cell are also analyzed with side scatter (SSC), which reflects the internal complexity of a cell and forward scatter (FSC), which is roughly proportional to cell size. The sample flow rate can be set to low, medium and high values, which correspond approximately to 12, 35 and 60 $\mu\text{l}/\text{minute}$, respectively.

- Three lasers - violet (405 nm), blue (488 nm) and red (640 nm)
- Multicolor analysis of up to 10 parameters

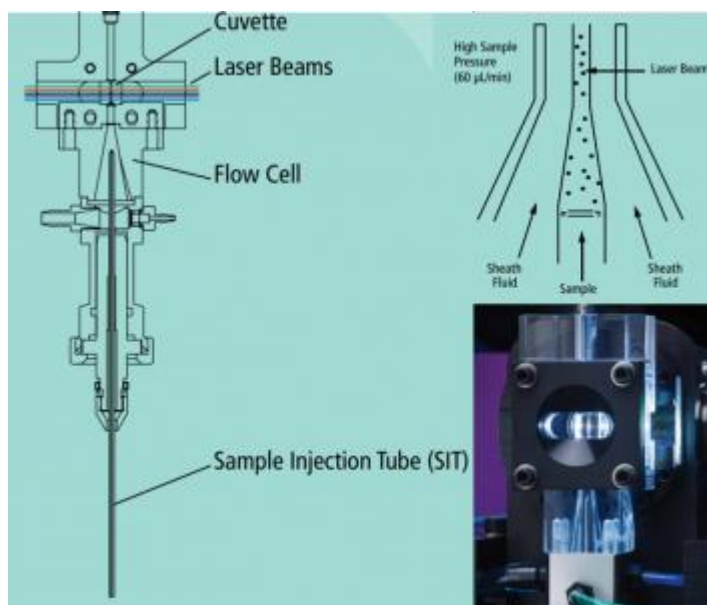

Configuration

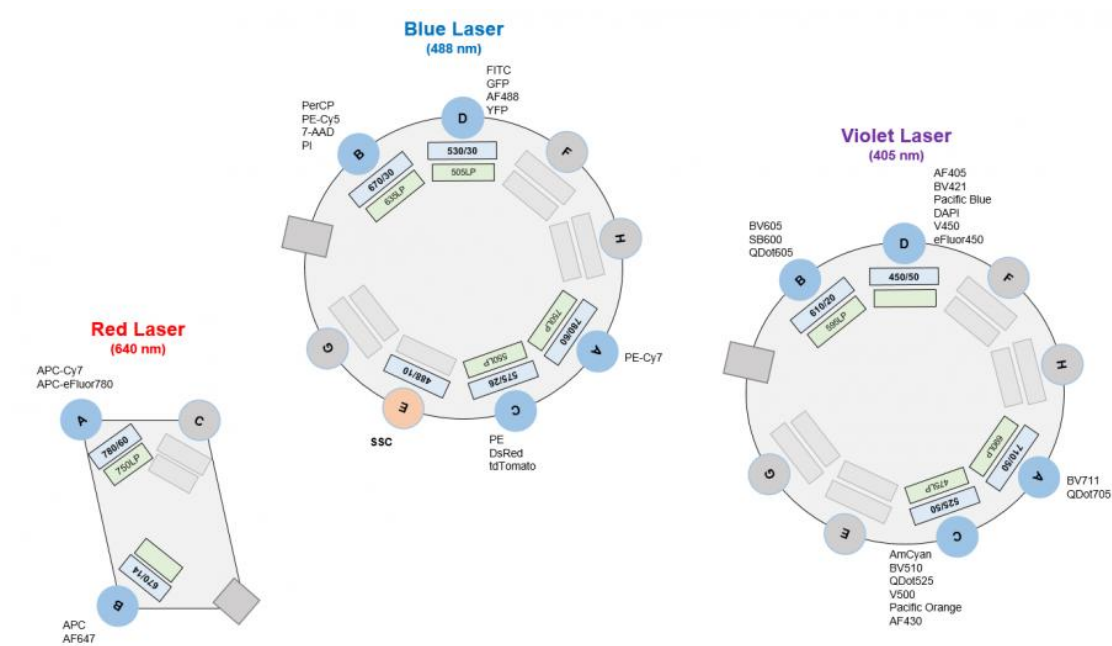

Fluorophores Compatibility

System	Laser	Detector	Filters	LP Filters	Fluorochromes
BD LSR Fortessa 1	Violet (405nm)	A	710/50	690LP	BV711, QDot 705
		B	610/20	595LP	BV605, SB600, QDot 605
		C	525/50	475LP	AmCyan, BV510, QDot 525, V500, Pacific Orange, AF430
		D	450/50		AF405, BV421, Pacific Blue, DAPI, V450, eFluor450
	Blue (488 nm)	A	780/60	750LP	PE-Cy7
		B	670/30	635LP	PerCP, PE-Cy5, 7-AAD, PI, PerCPCy5.5/PE-Cy5.5 with 695/40
		C	575/26	550LP	PE, DsRed, tdTomato, YFP with 542/27
		D	530/30	505LP	FITC, GFP, AF488, YFP, GFP with 510/20
		E	488/10		SSC
	Red (640nm)	A	780/60	750LP	APC-Cy7, APC-eFluor780, APC-AF750, APC-H7
		B	670/14		APC, AF647, Cy5, AF633

Additional filters (LSR Fortessa 1)		
BP	LP	Fluorochrome
510/20	505	GFP
542/27	525	YFP
670/30	635	PerCP
670/30	655	BV650
695/40	685	PerCP-Cy5.5/PE-Cy5.5
730/45	690	AF700
780/60	755	BV785

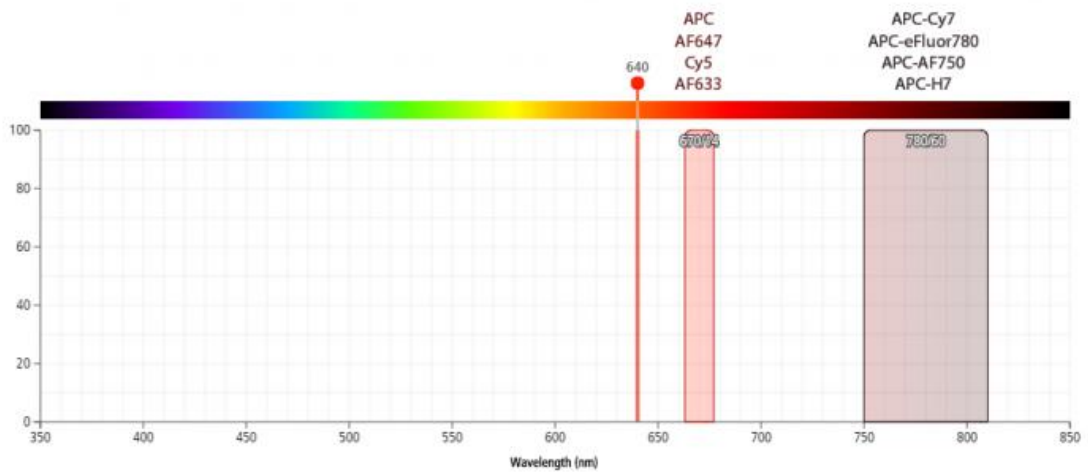
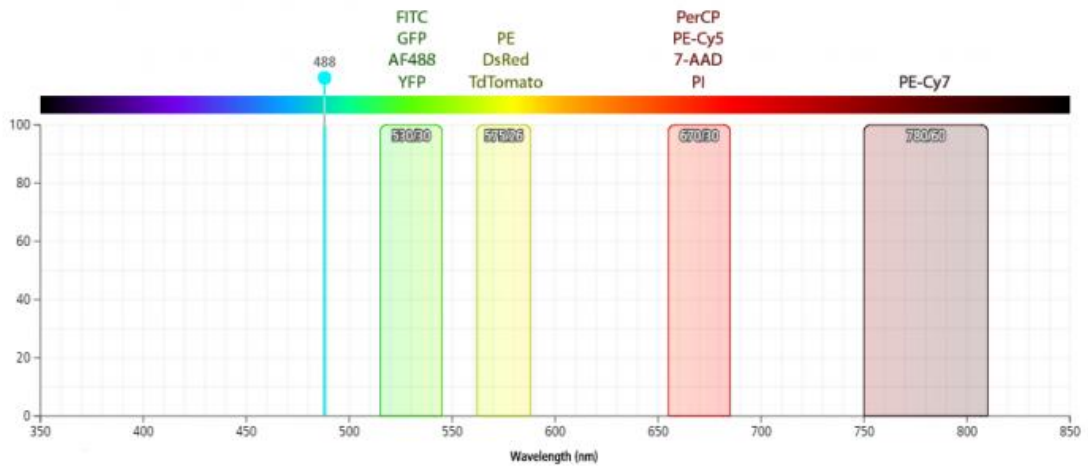
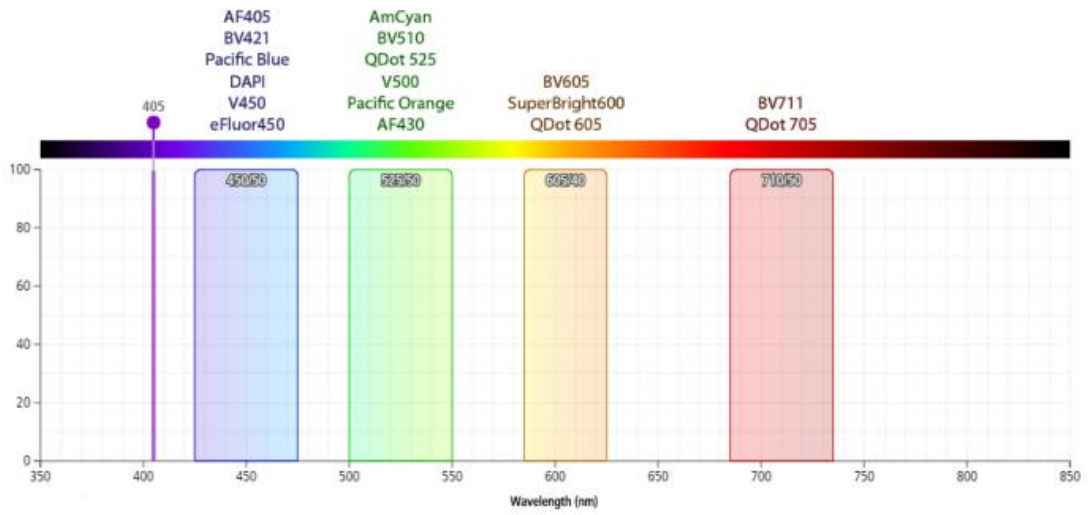

FACSAria™ III (Becton Dickinson) – 12 colours

Software: BD FACSDiva™

Performance

Fluorescence Sensitivity	FITC < 85 MESF values; PE < 29 MESF measurements performed at 70 psi and 90 kHz using SPHERO™ Rainbow Calibration Particles (RCP-30-5A)
Fluorescence Resolution	CV <3.0%, full G ₀ /G ₁ peak (area) for propidium iodide (PI)-stained chicken erythrocyte nuclei (CEN)
Fluorescence Linearity	Doublet/singlet ratio: CEN stained with PI: 1.95-2.05 (488-nm laser)
Forward and Side Scatter Sensitivity	Sensitivity enables separation of fixed platelets from noise, identification of bacteria, and detection of 0.5-µm beads
Forward and Side Scatter Resolution	Scatter performance is optimized for resolving lymphocytes, monocytes, and granulocytes
Sample Acquisition Rate	Maximum acquisition rate with 12 compensation pairs and 8 parameters: 10,000 events/second

Fluidics

Sample Flow Rates	Adjustable dynamic range of sample flow rates
Fluidic Cleaning Modes Included (Software)	<ul style="list-style-type: none">- Automated start up and shutdown- Clean flow cell- Prepare for aseptic sort
Nozzles	70, 85, 100 and 130-µm, removable and can be sonicated. A registered key-fit position at the bottom of the cuvette provides fixed stream alignment
Automated Cell Deposition Unit	ACDU for slide and plate sorting: 6, 24, 48, 96 and 384-well plates

Optics

Laser Excitation	488 nm, 405 nm and 640 nm
Forward Scatter Detector and Filters	Photodiode with 488/10 bandpass filter for the 488-nm laser
Side Scatter Detector	Photomultiplier with a 488/10 bandpass filter for the 488-nm laser

Laser	Detector	Mirror	Filter	Fluorochrome
Blue (488 nm)	A	750 LP	780/60 BP	PE-Cy7
	B	635 LP	695/40 BP	PerCP/PerCP-Cy5-5/ 7-AAD/PE-Cy5
	C	595 LP	616/23 BP	PE-Texas Red/PE-CF594
	D	550 LP	582/15 BP	PE
	E	495 LP	530/30 BP	FITC/GFP/Alexa488/BB515/CSFSE
	F		488/10 BP	SSC
Violet (405nm)	A	735 LP	780/60	Brilliant Violet 786
	B	685 LP	710/50	Brilliant Violet 711
	C	630 LP	660/20	Brilliant Violet 650
	D	600 LP	610/20	Brilliant Violet 605
	E	505 LP	525/50 BP	Brilliant Violet 510/ AmCyan/CFP/ Pac Orange/V500
	F		450/50 BP	Brilliant Violet 421/ Pacific Blue/Cascade blue/V450/VPD450
Red (640 nm)	A	750 LP	780/60 BP	APC-Cy7/APC-H7
	B	685 LP	730/45 BP	Alexa-700
	C		670/30 BP	APC/Alexa647

Sort Performance

Drop Drive Frequency	Range 1-100,000 Hz
Purity and Yield	At 70 psi and 90 kHz with an average threshold rate of 25,000 events per second, a four-way sort achieved a purity of >98% and a yield >80% of Poisson's expected yield
Sort Collection Devices	Two-way sorting: 12 x 75 mm, and 15 mL Four-way sorting: 1.5 mL microtube and 12 x 75 mm
BD FACS™ Accudrop	Red diode laser provided for fully automated drop-delay determination; Automated drop breakoff monitoring; Automated clog detection and sort tube protection system using Sweet Spot technology

Signal Processing

Converter	10-MHz Analog-to-Digital converter
Workstation Resolution	262,144 channels
Pulse Processing	Height, Area, and Width measurements available for any parameter. Ratio measurements are also available
Time	Time can be correlated to any parameter for kinetics experiments or other applications
Channel Threshold	Available for any parameter from any lasers with the ability to use multiple thresholds from different lasers simultaneously

Equipment acquisition was financed through the QREN - Centro Regional Operational Program 2007-2013 with the support of Mais Centro and the European Union under the project "CNC Biotech - Biotechnology research and business sector training".